

Register your device

Register your device to your **MyCAEN+** account and get access to our customer services, such as notification for new firmware or software upgrade, tracking service procedures or open a ticket for assistance. **MyCAEN+** accounts have a dedicated support service for their registered products. A set of basic information can be shared with the operator, speeding up the troubleshooting process and improving the efficiency of the support interactions.

MyCAEN+ dashboard is designed to offer you a direct access to all our after sales services. Registration is totally free, to create an account go to <https://www.caen.it/become-mycaenplus-user> and fill the registration form with your data.

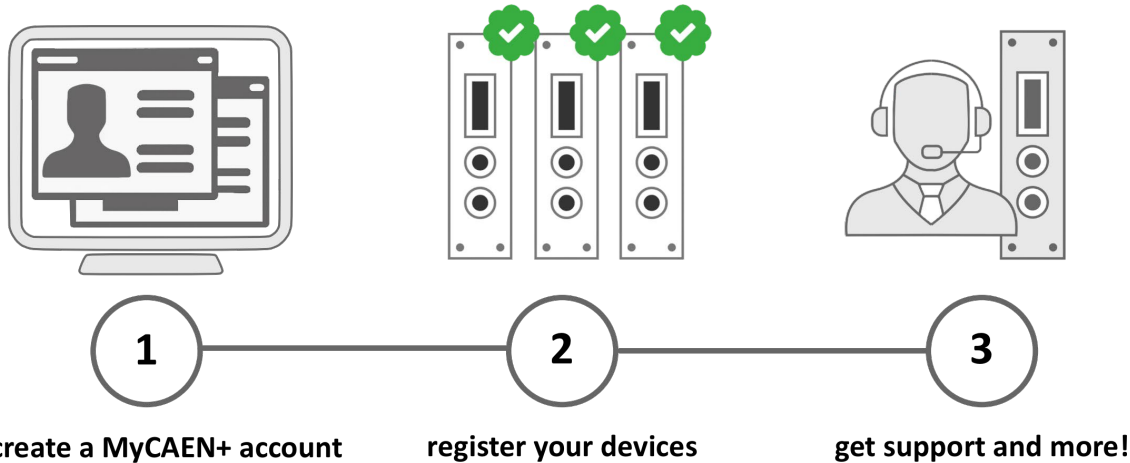

<https://www.caen.it/become-mycaenplus-user/>

Technical Information Manual

Revision n. 3

15 January 2003

MOD. V976 series
4 FOLD COINCIDENCE
FAN IN / FAN OUT
TRANSLATOR

NPO:

00110/00:V976x.MUTx/03

CAEN will repair or replace any product within the guarantee period if the Guarantor declares that the product is defective due to workmanship or materials and has not been caused by mishandling, negligence on behalf of the User, accident or any abnormal conditions or operations.

CAEN declines all responsibility for damages or injuries caused by an improper use of the Modules due to negligence on behalf of the User. It is strongly recommended to read thoroughly the CAEN User's Manual before any kind of operation.



CAEN reserves the right to change partially or entirely the contents of this Manual at any time and without giving any notice.

TABLE OF CONTENTS

1. MODULE DESCRIPTION.....	5
1.1 OVERVIEW.....	5
1.2 BLOCK DIAGRAM.....	7
2. TECHNICAL SPECIFICATIONS.....	8
2.1 PACKAGING.....	8
2.2 POWER REQUIREMENTS.....	8
2.3 FRONT PANEL.....	9
2.4 MECHANICAL AND ELECTRICAL FEATURES.....	10
2.5 TECHNICAL SPECIFICATION TABLES.....	11
3. FUNCTIONAL DESCRIPTION.....	12
3.1 CHANNEL AND CONTROL ORGANISATION.....	12
3.2 FUNCTION SELECTION.....	12
3.3 OUTPUT TYPE SELECTION.....	12
3.4 INPUT ENABLE SELECTION.....	13
3.5 OUTPUT LEVEL SELECTION.....	13
3.6 MAJORITY LOGIC.....	13
3.6.1 Majority logic selection.....	13
3.6.2 Majority level setting.....	13
3.7 DUTY CYCLE FINE ADJUSTMENT.....	14
4. OPERATING MODES.....	15
4.1 TTL-NIM/NIM-TTL TRANSLATOR.....	15
4.1.1 16 channel TTL-NIM translator.....	15
4.1.2 16 channel NIM-TTL translator.....	15
4.1.3 8 channel TTL-NIM translator + 8 channel NIM-TTL translator.....	15
4.2 AND/OR LOGIC FUNCTIONS.....	15
4.2.1 4 X (2, 3, 4) in / 4 out AND.....	15
4.2.2 4 X (2, 3, 4) in / 4 out OR.....	16
4.2.3 2 X (2, 3, 4) in / 4 out AND + 2 X (2, 3, 4) in / 4 out OR.....	16
4.3 MAJORITY FUNCTION.....	16
4.3.1 2 X (8 in / 8 out) Majority and 2 X (1 to 8) Fan out.....	16
4.3.2 16 in / 16 out Majority and 1 to 16 Fan out.....	16

LIST OF FIGURES

FIG. 1.1: MODEL TYPE LABEL (EXAMPLE: V976 B)	6
FIG. 1.2: MODEL V976 BLOCK DIAGRAM.....	7
FIG. 2.1: FRONT PANEL	9
FIG. 2.2: SIDE VIEW	11

LIST OF TABLES

TABLE 1.1: AVAILABLE VERSIONS	6
TABLE 2.1: POWER REQUIREMENTS	8
TABLE 2.2: TECHNICAL FEATURES.....	11
TABLE 2.3: SIGNAL SPECIFICATIONS	11
TABLE 3.1: FUNCTION SELECTION	14

1. Module description

1.1 Overview

The board is a 1-unit VME module housing four 4-input Coincidence, Fan in/Fan out and NIM – TTL Adapter sections.

The module has 16 inputs and 16 outputs on LEMO 00 connectors. Each section can either operate as a 4 channel NIM-to-TTL or TTL-to-NIM translator or perform the AND/OR logic functions.

The module works also as Fan out and supports the Majority logic function.

The board recognises automatically NIM and TTL signals (no input-type selection is necessary).

In more detail, the supported functions are the following:

- *16 ch TTL – NIM, NIM – TTL Translator*
- *8 ch TTL – NIM + 8 ch NIM – TTL Translator*
- *4 X (2, 3, 4 in / 4 out AND/OR)*
- *2 X (8 in / 8 out Majority)*
- *16 in / 16 out Majority*
- *2 X (1 to 8) Fan out*
- *1 to 16 Fan out*

The desired function can be selected via front-panel and internal switches.

Some extra functions can be obtained by cascading properly the module's sections .

The output signals are equal in duration to the time during which the performed logical operation has a TRUE status. The output width cannot thus be programmed.

Input signals can be indifferently either NIM or TTL levels; the outputs can be programmed to provide either NIM or TTL levels as well (either normal or negated, selectable via front panel switches).

The presence of incoming input signals is signalled by 16 green LEDs (one per channel).

The Majority LEDs light up when the Majority is being performed.

Table 1.1: Available versions

Version ¹	Jaux connector	-5 V DC-DC converter	Live insertion
V976 B	no	yes	yes



Fig. 1.1: Model type label (example: V976 B)

¹ A label on the printed board soldering side indicates the module's version (see Fig 1.1). All the versions share the same features except where indicated.

1.2 Block diagram

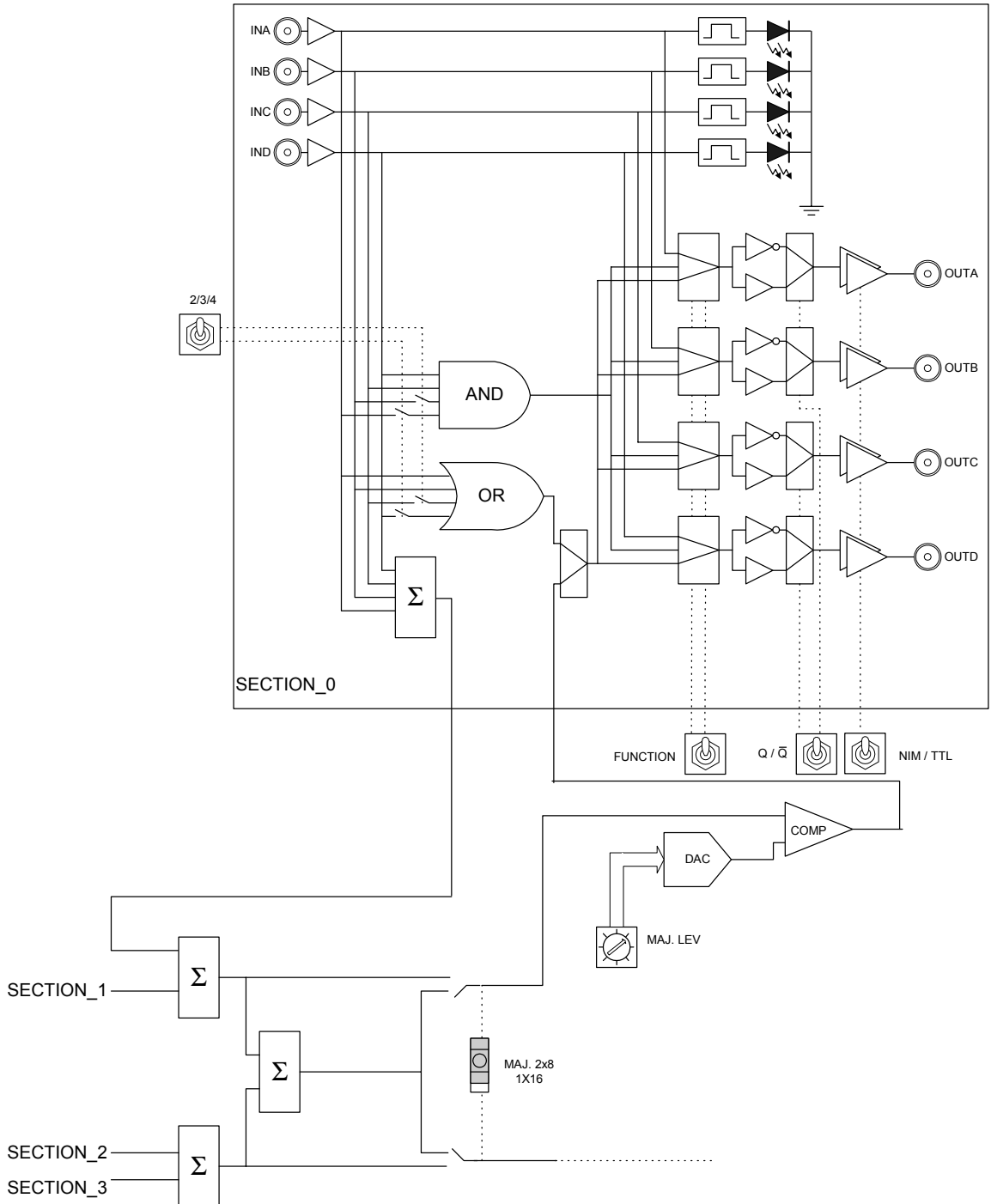

Fig. 1.2: Model V976 block diagram

2. Technical specifications

2.1 Packaging

The module is housed in a 6U-high, 1U-wide VME unit. The board hosts the VME P1 connector.

2.2 Power requirements

The power requirements of the module are as follows:

Table 2.1: Power requirements

+5 V	2.4 A
+12 V	20 mA

2.3 Front panel

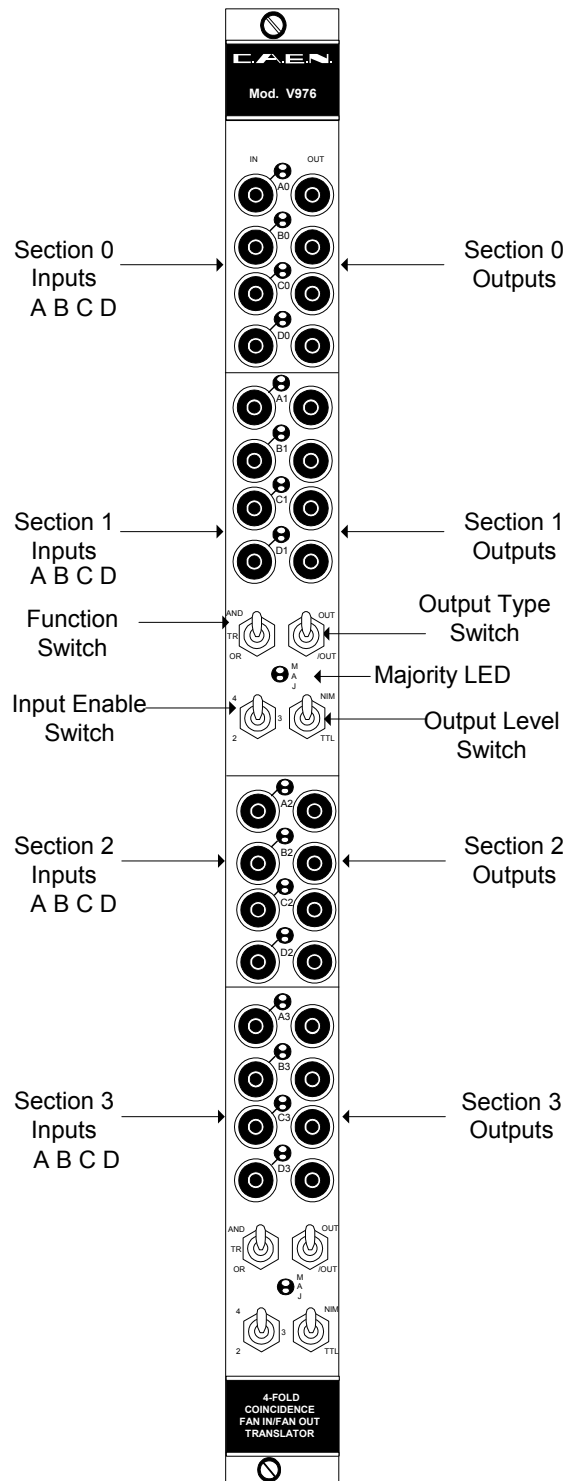

Fig. 2.1: Front panel

2.4 Mechanical and electrical features

INPUT CONNECTORS:

Mechanical specifications:

16 LEMO 00 type connectors

Electrical specifications:

NIM/TTL logic signals; 150 MHz maximum input frequency, 50 Ω impedance

OUTPUT CONNECTORS:

Mechanical specifications:

16 LEMO 00 type connectors

Electrical specifications:

NIM/TTL logic signals, normal or negated (switch selectable), 50 Ω impedance

DISPLAYS:

Channel LEDs: 16 green LEDs; they light up to signal the presence of incoming pulses

Majority LEDs: 2 red LEDs; they light up when the Majority is being performed

FRONT PANEL SWITCHES:

Function switches: two 3-position switches

Polarity switches: two 3-position switches

Input enable switches: two 3-position switches

Output sel. switches: two 2-position switches

INTERNAL SWITCHES:

Majority dip switch: one 2-position dip-switch

Majority rotary switches: two 16-position rotary switches

INTERNAL TRIMMERS:

Duty cycle trimmers: two screw trimmers

N.B.: Read carefully § 3 for a full description of the switches'/trimmers' usage.

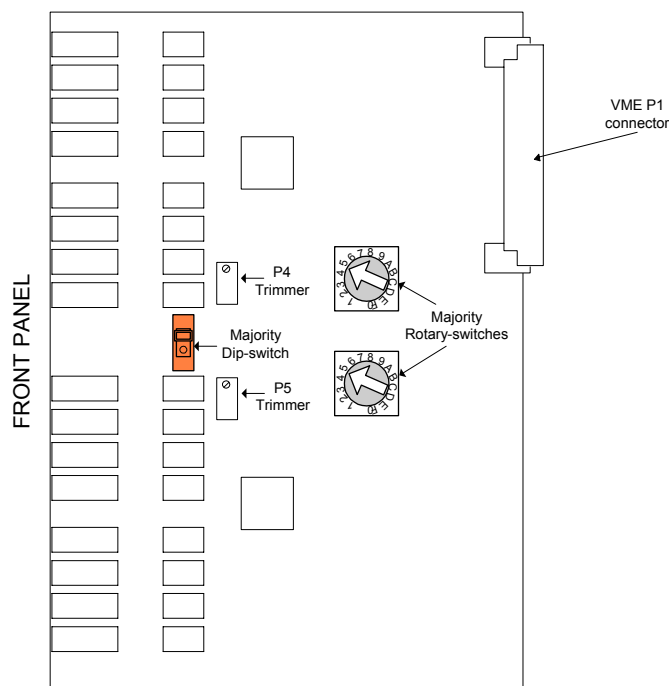

Fig. 2.2: Side view

2.5 Technical specification tables

Table 2.2: Technical features

Packaging	1U-wide VME unit
Input channels	16 NIM/TTL levels, 50 Ω impedance
Output channels	16 NIM/TTL normal/negated levels (switchable), to be terminated on 50 Ω
Min. coincidence width	2 ns
Min. input width	2 ns
Max. input frequency	150 MHz (translator mode, with NIM signals, normal output)
I/O delay	Translator: 9 ns; AND/OR: 11.5 ns
Double pulse resolution	8 ns
Output rise/fall time	NIM: 1/2 ns; TTL: 2/2.5 ns

Table 2.3: Signal specifications

	NIM		TTL	
	Max	Min	Max	Min
V0in	200 mV	-250 mV	700 mV	-200 mV
V1in	-600 mV	-2 V	5 V	1 V
V0out	-	-50 mV	30 mV	-
V1out	-700 mV	-	-	2.4 V

3. Functional description

3.1 Channel and control organisation

The board has four sections (0, 1, 2 and 3) housing four input channels (A, B, C and D) and four outputs each. Each 2-section group (Section 0 + Section 1 and Section 2 + Section 3) is provided with four front panel switches: one for the function selection (3-position, see § 3.2), one for the output type (3-position, see § 3.3), one for selecting the inputs to be sent to the logical ports (3-position, see § 3.4) and finally one for selecting the output level (2-position, see § 3.5). The PCB houses two rotary switches for the Majority setting; such controls operate over a 2-section group (Section 0 + Section 1 and Section 2 + Section 3) each (see § 3.6.2). One dip switch on the PCB (see § 3.6.1) allows to sum the two groups during Majority logic operation. For any operation the output pulse width equals the time during which the relevant operator (AND, OR, TR and MAJ) has a TRUE status.

3.2 Function selection

Each 2-section group has a 3-position front panel switch which allows to select the function to be performed:

- AND:** The Logical AND of the selected inputs (see § 3.4) is provided on each output channel of the relevant section.
- TR:** The selected signal type is provided on an output channel, when either a NIM or a TTL signal is present on the relevant input.
- OR:** The Logical OR of the selected inputs (see § 3.4) is provided on each output channel of the relevant section.

N.B.: The relevant Majority Rotary Switch (see § 3.6.2) must be set to 0, when the OR is performed

3.3 Output type selection

Each 2-section group has a 3-position switch which allows to select the output type:

- Up (OUT):** A, B, C, D: normal
- Middle (no label):** A, B: normal; C, D: negated
- Down (/OUT):** A, B, C, D: negated

3.4 Input enable selection

Each 2-section group has a 3-position front panel switch which allows to select the inputs channels to be sent to the logical ports; this switch is meaningless when the translation function (TR) is selected (see § 3.2) and when the Majority is performed:

- 2: A, B input selected (C, D ignored)
- 3: A, B, C input selected (D ignored)
- 4: A, B, C, D input selected

3.5 Output level selection

Each 2-section group has a 2-position front panel switch which allows to select the output levels:

- TTL: TTL level output
- NIM: NIM level output

3.6 Majority logic

3.6.1 Majority logic selection

The module has a 2-position internal dip switch which allows to obtain either a 2x8 or a 16 channel majority logic (see § 4.3):

dot visible: 2x8 Majority logic

dot not visible: 1x16 Majority logic

The output is TRUE whenever the number of TRUE inputs is greater than the selected majority level (see § 3.6.2); it is provided on each output channel of the sections which are performing the Majority.

3.6.2 Majority level setting

Each 2-section group has a 16-position internal rotary switch which allows to set the majority level:

MAJORITY LEVEL: from 1 to 10

The majority level must be set in the 1÷8 range if the 2x8 Majority logic is used, 1÷10 when the 1x16 Majority logic is used (see § 4.3).

Note that:

- The Function switch must be on the **OR** position when the Majority is performed
- The rotary switches have actually 15 position, but any position >10 is equal to 10
- When the Majority Level is set to **0**, the module performs the OR function
- When the Majority is performed (Majority Level ≥ 1), the relevant LEDs light up

Table 3.1: Function selection

Function	Nr. of gates	Nr. of input per gate	Nr. of output per gate	Function switch	Input enable switch	Rotary switch	Dip switch
Translator	16	1	1	TR	-	-	-
AND 4	4	4	4	AND	4	-	-
AND 3	4	3	4	AND	3	-	-
AND 2	4	2	4	AND	2	-	-
OR 4	4	4	4	OR	4	0	-
OR 3	4	3	4	OR	3	0	-
OR 2	4	2	4	OR	2	0	-
MAJ 16	1	16	16	OR	-	1÷10	1x16
MAJ 8	2	8	8	OR	-	1÷8	2x8

3.7 Duty cycle fine adjustment

Two screw trimmers (P4 and P5 in Fig. 2.2) allow the fine adjustment of the duty cycle of the output with respect to the input. The factory setting is optimized for a 100 MHz NIM input and NIM normal output (output type: OUT, see § 3.3).

4. Operating modes

4.1 TTL-NIM/NIM-TTL translator²

4.1.1 16 channel TTL-NIM translator

This function can be performed by placing both the “Function” switches (see § 3.2) on the “TR” position and the “Output Level” switches (see § 3.5) on “NIM”. The “Output Type” switches (see § 3.3) allow to obtain either normal or negated output signals.

4.1.2 16 channel NIM-TTL translator

This function can be performed by placing both the “Function” switches on the “TR” position and the “Output Level” switches on “TTL”. The “Output Type” switches allow to obtain either normal or negated output signals.

4.1.3 8 channel TTL-NIM translator + 8 channel NIM-TTL translator

This function can be performed by placing both the “Function” switches on the “TR” position, the upper “Output Level” switch on “NIM” and the lower “Output Level” switch on “TTL”. The “Output Type” switches allow to obtain either normal or negated output signals.

4.2 AND/OR³ logic functions

4.2.1 4 X (2, 3, 4) in / 4 out AND

These functions can be performed by placing both the “Function” switches on the “AND” position, the “Input Enable” switches on either “2”, “3” or “4”, according to how many input signals participate to the AND logic. The “Output Level” switches can be placed either on “NIM” or on “TTL” at will, as well as the “Output Type” ones can be either normal or negated.

² When the module is used as a Translator, the “Input Enable” (see § 3.4) switches’ setting is ignored

³ Make sure that the Majority Level is set to 0 when the OR function is performed

4.2.2 4 X (2, 3, 4) in / 4 out OR

These functions can be performed by placing both the "Function" switches on the "OR" position, the "Input Enable" switches on either "2", "3" or "4", according to how many input signals participate to the OR logic. The "Output Level" switches can be placed either on "NIM" or on "TTL" at will, as well as the "Output Type" ones can be either normal or negated.

4.2.3 2 X (2, 3, 4) in / 4 out AND + 2 X (2, 3, 4) in / 4 out OR

These functions can be performed by placing the upper "Function" switch on the "AND" position and the lower one on the "OR" position, the "Input Enable" switches on either "2", "3" or "4", according to how many input signals participate to the AND/OR logic. The "Output Level" switches can be placed either on "NIM" or on "TTL" at will, as well as the "Output Type" ones can be either normal or negated.

4.3 Majority function⁴

4.3.1 2 X (8 in / 8 out) Majority and 2 X (1 to 8) Fan out

This function can be performed by placing both the "Function" switches on the "OR" position. Then the "Majority rotary switches" (see § 3.6.2) must be set in the 1÷8 range, the "Majority dip switch" (see § 3.6.1) must be placed on the "2x8" (dot visible) position. The "Output Level" switches can be placed either on "NIM" or on "TTL" at will, as well as the "Output Type" ones can be either normal or negated. An output signal is produced on each output connector, anytime the number of active inputs is either equal or greater than the set Majority Level.

This operating mode allows to use the module as a **2 x (1 to 8) Fan out**, simply by setting the Majority Level to 1.

4.3.2 16 in / 16 out Majority and 1 to 16 Fan out

This function can be performed by placing both the "Function" switches on the "OR" position. Then the "Majority rotary switches" must be set in the 1÷10 range, the "Majority dip switch" must be placed on the "1x16" (dot not visible) position. The "Output Level" switches can be placed either on "NIM" or on "TTL" at will, as well as the "Output Type" ones can be either normal or negated. An output signal is produced on each output connector, anytime the number of active inputs is either equal or greater than the set Majority Level.

This operating mode allows to use the module as a **1 to 16 Fan out**, simply by setting the Majority Level to 1.

⁴ When the module performs the Majority, the "Input Enable" (see § 3.4) switches' setting is ignored

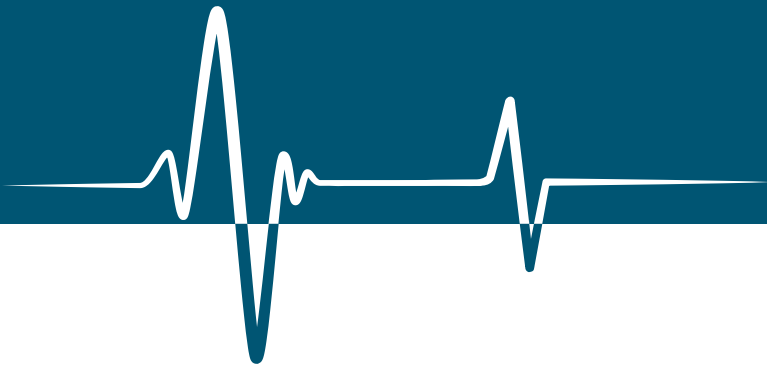

CAEN S.p.A.

Via Vetraia 11
55049 - Viareggio
Italy
Phone +39 0584 388 398
Fax +39 0584 388 959
info@caen.it
www.caen.it

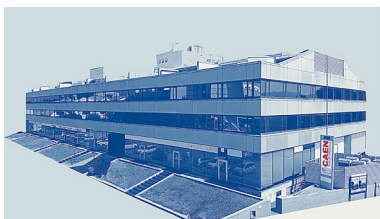

CAEN GmbH

Brunnenweg 9
64331 Weiterstadt
Germany
Tel. +49 (0)212 254 4077
Mobile +49 (0)151 16 548 484
info@caen-de.com
www.caen-de.com

CAEN Technologies, Inc.

1 Edgewater Street - Suite 101
Staten Island, NY 10305
USA
Phone: +1 (718) 981-0401
Fax: +1 (718) 556-9185
info@caentechnologies.com
www.caentechnologies.com

CAENspa INDIA Private Limited

B205, BLDG42, B Wing,
Azad Nagar Sangam CHS,
Mhada Layout, Azad Nagar, Andheri (W)
Mumbai, Mumbai City,
Maharashtra, India, 400053
info@caen-india.in
www.caen-india.in



Copyright © CAEN SpA. All rights reserved. Information in this publication supersedes all earlier versions. Specifications subject to change without notice.